

Elixo 500 230 V RTS

Motorization for sliding gates

UP TO 8 M | 500 KG



Motor ground fixation

Reliable and hard-wearing
for sliding gates

- Easy to install
 - > Easy access to ground fixation screws from the top
 - > No adjustment needed from the installer
- Reliability and durability
 - > Mechanical design based on 30 years of group experience
 - > Suitable for regular use and tested for 180,000 openings and closings
- Convenient to use
 - > Easy key unlocking from inside

Packs

							
	Elixo 500 230 V RTS motor	Keygo RTS	Amber light Master Pro 230 V blinking	Keytis ^{MS} 2 RTS	Amber light Eco Pro	Photocells Master Pro Bitech	Packs per pallet
		Ref. 1841064	Ref. 9015034	Ref. 1780799	Ref. 9018754	Ref. 1841155	

Standard pack Ref. 1216367	•	● 2x	-	-	-	-	36
Comfort pack Ref. 1216368	•	● 2x	•	-	-	•	36
Comfort pack ME Ref. 1216419	•	-	-	● 2x	•	•	36
Standardpack ME Ref. 1216420	•	-	-	● 1x	-	•	36
Comfort pack ME PALLET Ref. 1216419	•	-	-	● 2x	•	•	36



Standard installation

1. Elixo 500 230 V RTS
2. Amber light
3. Outdoor antenna

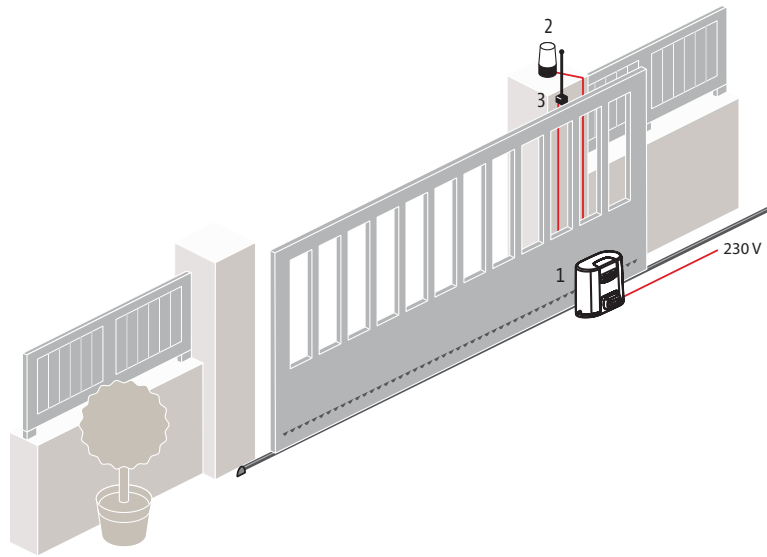

General overall size

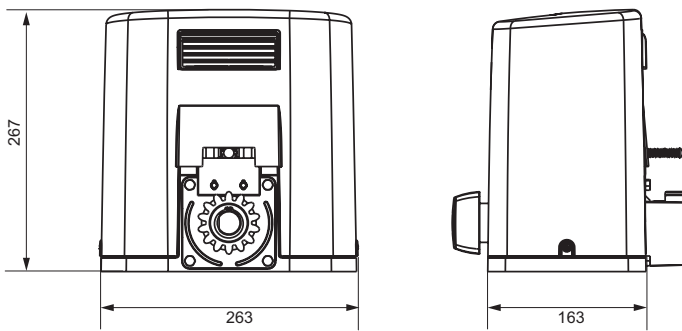

Technical characteristics

Mains power supply	230 V (-15% / +10%) - 50 Hz	RTS radio frequency	433.42 MHz
Motor voltage	230 V	Number of remote controls	36 channels maximum
Maximum power consumption	290 W	Index of protection	IP 44
Accessories power supply	24 Vdc / 200 mA	Operating temperature	-20°C to +60°C
Maximum number of operations/day	100	Tested for	180,000 openings and closings
Opening time to 3 m	21 s		

Special accessories



Radio keypad metal RTS

Ref. 1841111 (France)
Ref. 1841116 (International)



1 meter of steel-reinforced nylon rack

Ref. 9011090 (Top fastening)
Ref. 9011089 (Bottom fastening)



Passive safety edge

Ref. 9014597 (Narrow profile 1)
Ref. 9014598 (Wide profile 2)